



**PLANMECA**  
ProMax 3D Max



*Profound understanding of anatomy*

The unique Planmeca ProMax 3D product family offers equipment for all maxillofacial imaging. All volume sizes from the smallest special cases to whole head images are available. Planmeca ProMax 3D Max, the dedicated CBVT X-ray unit, is designed to obtain complete information on patient anatomy in the minutest detail. With a maximum field of view (FOV) of  $\text{Ø}23 \times 26 \text{ cm}$ , it offers entirely new possibilities in diagnostics. Advanced imaging software tools maximise the benefits.





Detailed diagnostics with 3D imaging

Planmeca ProMax 3D Max features direct deposit semiconductor flat panel with CsI scintillator which produces accurate, distortion-free images for 3D reconstruction. Unlike image intensifier sensors that use old vacuum tube technology and multi-step focusing, flat panels use single step image readouts with no geometric distortion, no loss of sensitivity, and therefore no need for frequent calibration.

Planmeca's proprietary 3D reconstruction algorithm converts the original 2D transillumination images to a 3D volume study, making it the core component for high quality 3D imaging. The algorithm handles high contrast

objects, eliminating effectively the artefacts caused by implants, metal fillings or braces.

The reconstructed image volume consists of hundreds of millions of voxels. These voxels are isotropic, enabling accurate 1:1 measurements and ensuring geometric relations throughout the image. The extremely small voxel size ( $100^3 / 200^3 / 400^3 / 600^3 \mu\text{m}^3$ ) produces a detailed high-resolution 5 lp/mm (theoretical maximum) image without artefacts.

In modern dentistry, the demand for implant surgery is steadily growing, which has created a need for more advanced X-ray imaging systems. To meet the needs of

modern surgical dentistry and to supply clear, dependable imaging in a three-dimensional format with limited patient radiation dose, Planmeca ProMax 3D Max utilises Cone Beam Volumetric Tomography (CBVT) technology. This innovative, versatile, and dynamic imaging device will open up new possibilities for on-site dentists.

Cone beam scan is ideal for dedicated imaging of the maxillofacial complex as it uses a pyramid-shaped beam to scan the entire region of interest in a single semicircle scan, as opposed to a medical CT that takes multiple axial slices in multiple full circle scans. The volumes are manipulated by computer software into one cylindrical image for viewing. During the scan, each image is

generated using a short X-ray pulse instead of continuous radiation. The total scanning time is 18 seconds for one volume, but the actual exposure time is only 3 seconds at shortest.

This technology reduces patient radiation dose considerably and forms stroboscopic X-ray effect which virtually eliminates artefacts, contributing to outstanding image quality.

The Planmeca ProMax platform's unique SCARA technology (Selectively Compliant Articulated Robot Arm) enables free geometry based on image formation. Planmeca's patented, computer-controlled SCARA

robotic arm can produce any movement pattern required, ensuring perfectly accurate and reliable image volume positioning and enabling image volume diameter adjustment. All controls are accessed via a full colour graphical user interface in the language of your choice.

Planmeca ProMax 3D Max is equipped with an automatic vertically driven patient positioning system, which takes stitching of several basic volumes into a new level. The patient positioning system keeps the patient stationary while the unit drives from imaging position to another. Thanks to this, the imaging is more straightforward and accurate than previously.

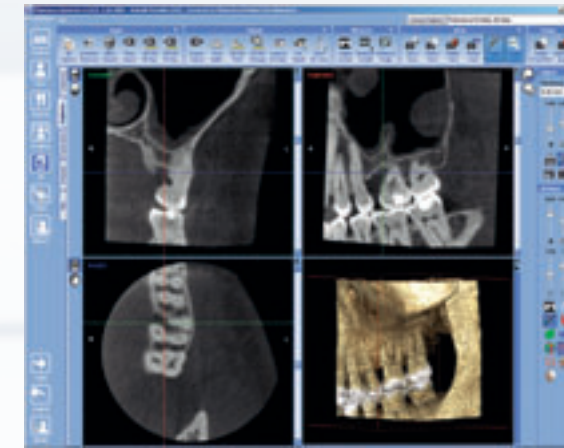

**Bone resorption and sinus**  
Bone resorption found on maxillary molar and two cysts in sinus.

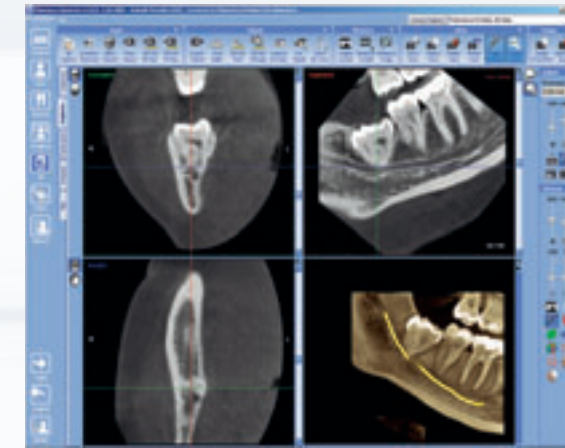

**Wisdom tooth case**  
The extraction of the tooth would be difficult. The tooth is lying just on the mandibular canal.

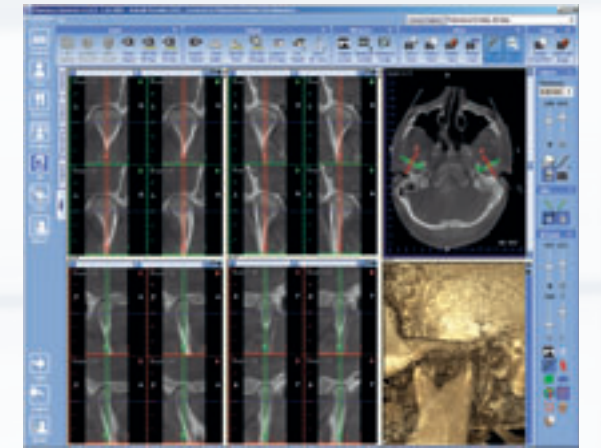

**TMJ case**  
Both condyles can be seen simultaneously in the TMJ module.

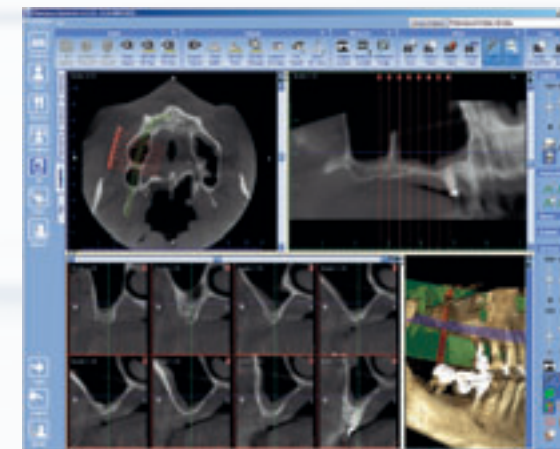

**Implant case.**  
Not enough bone for an implant. Sinus grafting is needed.

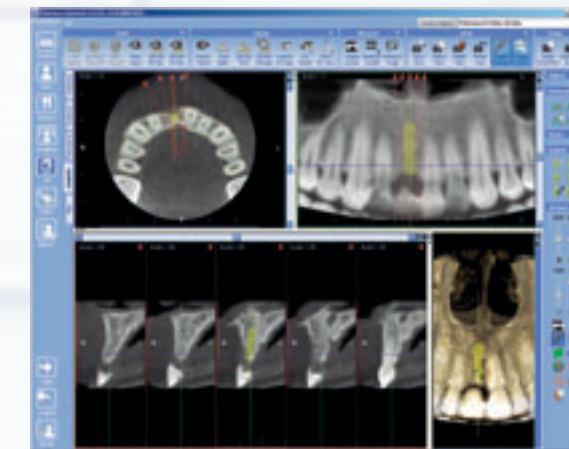

**Implant case.**  
Enough bone exists for an implant.

Planmeca ProMax 3D Max complies with a multitude of diagnostic requirements: those of endodontics, periodontics, orthodontics, implantology, as well as dental and maxillofacial surgery, and TMJ analysis.

With Planmeca ProMax 3D Max, imaging any region of interest in the maxillofacial region is effortless, as the volume sizes include everything from full maxillofacial image size (Ø23 x 26 cm) to the smallest size (Ø5 x 5,5 cm) intended for single tooth imaging.

Planmeca ProMax 3D Max produces high-resolution volumetric studies of the mandible and maxilla for analysing the available bone structure, the location

of the mandibular canal, and the correct position for the implant. Pre-surgical planning will reach a new level of precision, as the prospective site becomes visible in all three imaging planes: sagittal, axial, and coronal.

Third molars, maxillary cuspids, supernumerary teeth, and impactions challenge the clinician to identify the tooth's orientation. By using Planmeca ProMax 3D Max, all angles and orientations become clearly visible.

Planmeca ProMax 3D Max studies provide full visualisation of all classes of orthodontic malocclusion. This is highly advantageous in orthodontic planning,

as time is saved and patient radiation dose reduced. Planmeca ProMax 3D Max provides the image data in the correct anatomic 1:1 ratio, with no need to correct for geometric magnification.

Planmeca ProMax 3D Max also provides high-resolution TMJ studies for true and accurate evaluations of the joint arthritides, condylar morphology, and the condyle-fossa relationship.

With its high resolution (5 lp/mm) and advanced reconstruction technology, Planmeca ProMax 3D Max establishes the new standard for 3D dental radiology.

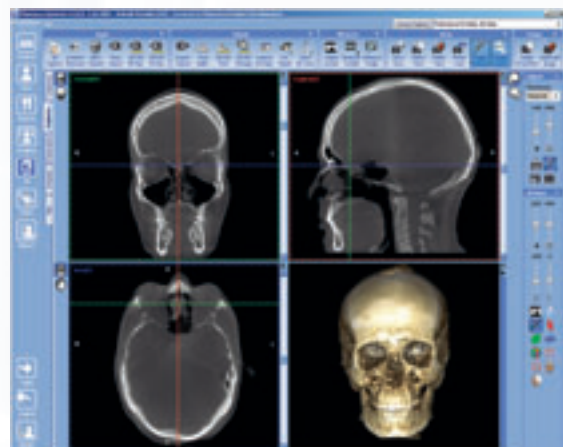

Planmeca Romexis Explorer view of a maximum image size

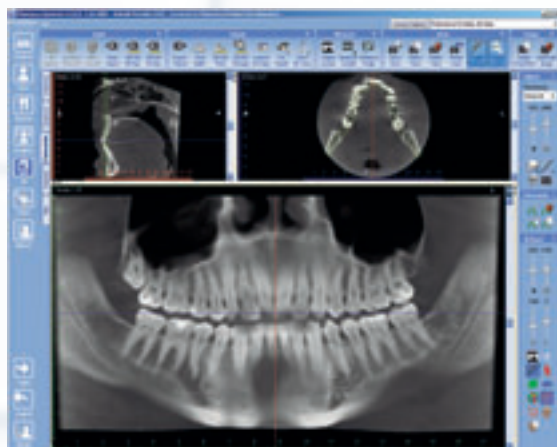

Planmeca Romexis panoramic view



Planmeca Romexis 3D Cross Sections module and 3D Implant Planning module

Planmeca Romexis 3D Explorer, the 3D image acquisition software for Planmeca ProMax 3D concept, enables flexible viewing in all three relevant projections: axial, coronal, and sagittal. The software incorporates a re-slicing feature, which enhances the projections and enables real-time three-dimensional viewing from the desired angle. A rendered 3D view provides a realistic overview of the anatomy.

With the Planmeca Romexis 3D Explorer software, each patient study can be stored on a CD with Planmeca Romexis Viewer for others to view.

The Planmeca Romexis 3D Cross Sections module produces cross-sectional images of anatomy along with the defined panoramic curve. The image number and their exact positions can be freely chosen.

The 3D Cross Sections module also includes reconstructed panoramic view, which creates a panoramic image from the acquired volume of data without the undesired artefacts, commonly visible in normal panoramic images. As the image is reconstructed through software, the user can determine the location and thickness of the focal trough.

The optional Planmeca Romexis 3D Implant Planning module offers superior tools for implant placing and nerve drawing. Implant library containing realistic implant models from a variety of manufacturers greatly assist the treatment planning. The drawing tool allows clear marking of the mandibular nerve.

Planmeca Romexis software supports DICOM standard, which allows 3D studies to be transferred to other

implant planning software or any other software that receives images in DICOM format. Studies can also be transferred to PACS or to a high quality DICOM printer in the network. For quick remote diagnostics, all images can be sent to iPhone and iPad with one click. The image data can also be used for ordering Planmeca ProModel, a patient specific physical model that serves as a beneficial tool for preoperative planning of advanced implant, oral and maxillofacial surgeries.

Planmeca Romexis is pure Java based software that runs in modern web environments and supports Windows and Mac OS operating systems: as all Planmeca X-ray units are fully compatible with both systems, the user may acquire, view, process, and store images in the operating system of his choice.



*Planmeca Romexis for accurate diagnosis*

### Planmeca Romexis software

Planmeca Romexis is a complete dental imaging software, including all dental imaging modalities: intraoral, panoramic, cephalometric, 3D imaging, dental tomography as well as intraoral video and still camera imaging. With a complete set of tools for image viewing, enhancement, measurements, and annotations, Planmeca Romexis also improves the diagnostic value of radiographs. Printing, image import and export, and DICOM functionalities are also included.

Planmeca Romexis platform fully integrates digital imaging with the patient's other clinical data. The system provides direct image capture from Planmeca's X-ray equipment, and interfaces with 3<sup>rd</sup> party devices via TWAIN. Together with Planmeca's X-ray equipment, Planmeca Romexis provides a unique safety feature especially useful for teaching environment: the X-ray image capture is inhibited until the supervisor has approved the student's image capture request.

### Planmeca Romexis computer recommendations

	Planmeca Romexis client workstation	Planmeca Romexis server
Processor	2 GHz Core Duo or equivalent	3 GHz Core Duo or equivalent
RAM	4 GB	4 GB
Hard disk space	40 GB	2 x 500 GB (RAID1 mirroring)
Graphics card	ATI or NVIDIA, 128 MB minimum memory	Not required
Monitor	1280 x 1024	1024 x 768
Peripherals	CD R/W or DVD R/W drive	CD R/W or DVD R/W drive
Backup medium	None necessary	DAT or equivalent
Operating system	Windows Vista (64 bit) Windows 7 (64 bit) Mac OS X	Windows XP Pro (32 bit) Windows 2003 (32 or 64) Windows Vista (32 or 64) Windows 7 (32 or 64)
Other	Java platform (Java Virtual Machine 1.6 or later)	Java platform (Java Virtual Machine 1.6 or later)

The disk space requirements are determined by digital images. Thus the space requirements vary, but a rough estimate is in the order of 1 MB per 2D X-ray image, 7–9 MB per extraoral image, depending on a variety of image specific factors, and 250 MB per 3D image.

It is recommended to use the same computer as an application server and as a database server. If Planmeca Romexis server computer is also used for client activities, the hardware should meet both client and server specifications.

These specifications are recommended minimum requirements. Not meeting them may lead to degraded performance.

### DICOM compatibility

- Media Storage – saving images into removable DICOM media
- Print – printing images on film or paper with a DICOM medical printer
- Storage – saving images into DICOM image archive
- Query/ Retrieve – importing digital images from DICOM image archive
- Worklist – importing a patient list from DICOM patient management
- Storage Commitment – confirmation of a successful image storage

### Planmeca ProMax 3D Max

X-ray beam	Cone
Focal spot	0.5 mm, fixed anode
Image detector	Amorphous silicon flat panel with CsI scintillator
Gray scale	15 bit
Detector resolution	1516 x 1900 pixels, pixel size 127 µm x 127 µm
Voxel size	100 x 100 x 100 µm, isotropic 200 x 200 x 200 µm, isotropic 400 x 400 x 400 µm, isotropic 600 x 600 x 600 µm, isotropic
Image acquisition	210 / 360 degree rotation
Total scan time	18–26 s, pulsed X-ray
Reconstruction time	30–150 s
Standard volumes (diam. x height)	Ø230 x 160 mm (child mode Ø230 x 160 mm) Ø100 x 130 mm (child mode Ø85 x 110 mm) Ø100 x 90 mm (child mode Ø85 x 75 mm) Ø100 x 55 mm (child mode Ø85 x 50 mm) Ø50 x 55 mm (child mode Ø42 x 50 mm)
Stitched volume (diam. x height)	Ø230 x 260 mm (child mode Ø230 x 260 mm)
3D reconstruction server	Proprietary Feldkamp type back projection reconstruction algorithm  Improved Artefact Removal (IAR) for high contrast object compensation

### Example installation

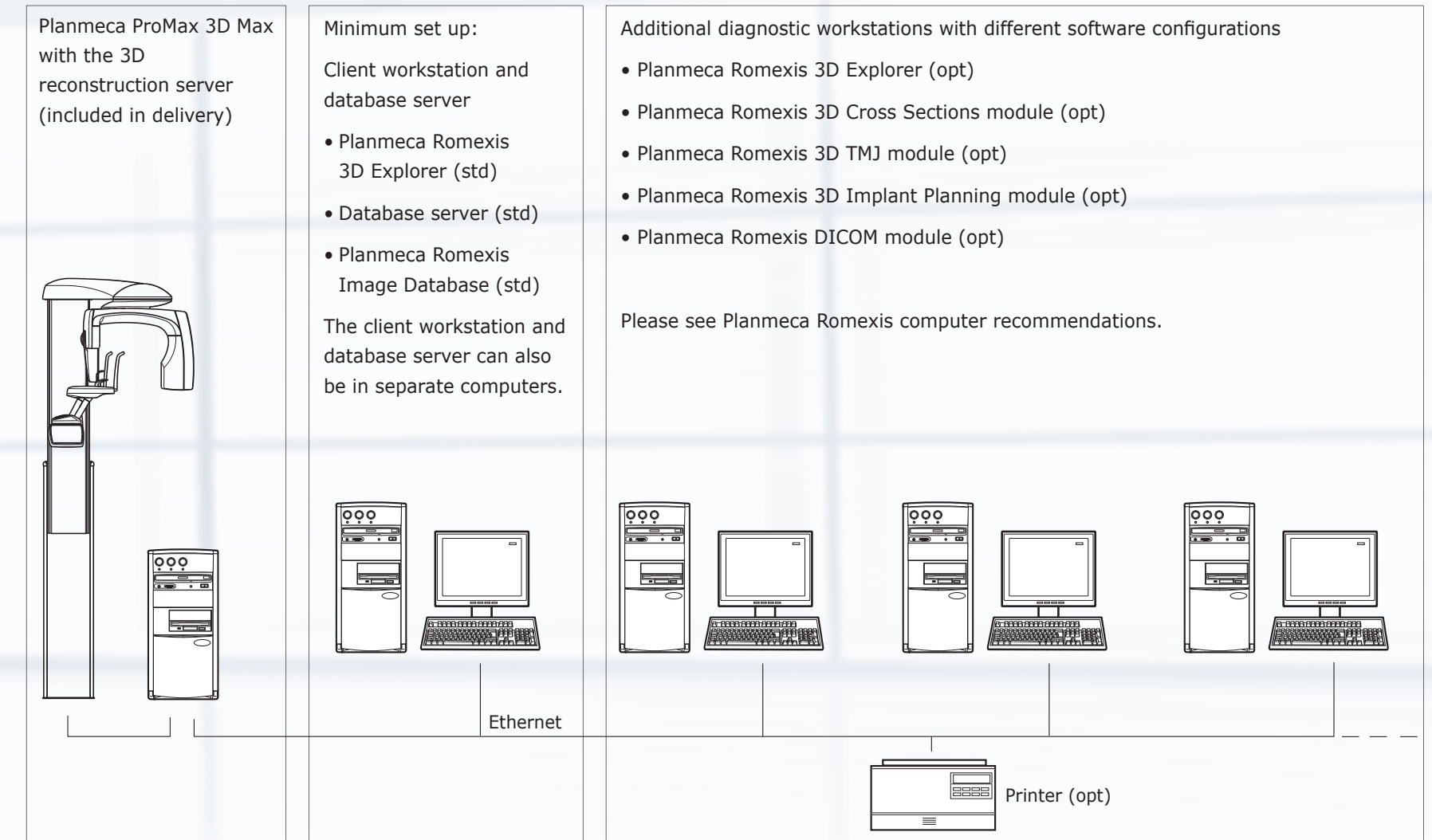

### Dimensions and space requirements

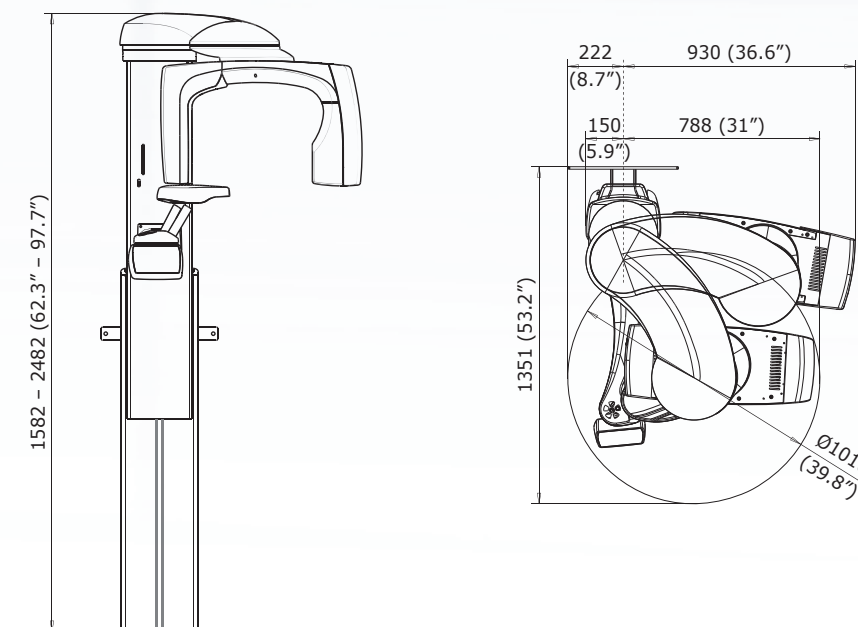

		Planmeca ProMax 3D Max
Physical space requirements	Width	116 cm (46 in.)
	Depth	136 cm (54 in.)
	Height*	159–249 cm (63–98 in.)
Minimum operational space requirements	Width	156 cm (62 in.)
	Depth	174 cm (69 in.)
	Height*	249 cm (98 in.)
	Weight	134 kg (lbs 296)

\*The maximum height of the unit can be adjusted for offices with limited ceiling space.



*Planmeca Oy designs and manufactures a full line of high technology dental equipment, including dental care units, panoramic and intraoral X-ray units, and digital imaging products. Planmeca Oy, the parent company of the Finnish Planmeca Group, is strongly committed to R&D, and is the largest privately held company in the field.*



Planmeca Oy  
 Asentajankatu 6 | 00880 Helsinki | Finland  
 tel. +358 20 7795 500 | fax +358 20 7795 555  
 sales@planmeca.com | www.planmeca.com

Images may contain optional items not included in standard delivery. Available configurations and features may have country or area specific variations. Some products displayed above may not be available in all countries or areas. Rights for changes reserved.